



**TESTIMONY OF KUSHAL PATEL**

**PARTNER, ENERGY AND ENVIRONMENTAL ECONOMICS, INC. (E3)**

**U.S. HOUSE OF REPRESENTATIVES**

**ENERGY AND COMMERCE COMMITTEE**

**ENERGY SUBCOMMITTEE**

**Hearing entitled “Powering America: The Role of Energy Storage in the Nation’s Electricity System”**

**July 18, 2018**

## Executive Summary

Thank you very much for the invitation to testify at this hearing on the role of energy storage in the nation’s electricity system. My name is Kushal Patel and I am a Partner at Energy and Environmental Economics, Inc. (“E3”), a consulting firm based in San Francisco, California, that focuses exclusively on energy issues and has studied energy storage for over 20 years.

Energy storage has been called the “Swiss Army knife” of the electric grid in recognition of the many services it can perform. Energy storage is expected to play an ever-larger role in our electric grid because of the variety of benefits it can provide to customers, utilities, and the wholesale markets. These include helping to manage individual customers’ electric bills; helping to lower utilities’ infrastructure costs (which benefits utility ratepayers); and helping to lower wholesale system operating costs (which benefits

consumers), particularly as larger amounts of renewable and less-emitting energy sources come online in the future. However, the barriers facing energy storage are substantial. These include high (but declining) costs and, more importantly, the limited ability for storage to earn revenues for the numerous services it can perform. Today, clear routes to market exist for only a limited number of storage services; others cannot currently be monetized, while still others, such as those related to integrating larger amounts of renewable energy, may not become valuable until the future and only in certain jurisdictions.

I recently assisted several New York State agencies with the development of the **New York Energy Storage Roadmap**<sup>1</sup>, a first-of-its-kind, analytically driven set of recommended policy, regulatory, and programmatic actions to help New York achieve its target of installing 1,500 megawatts (MW) of advanced energy storage by 2025, as per a recent announcement by Governor Andrew M. Cuomo. The roadmap found that many customer-sited and distribution system energy storage use cases and paired solar + storage projects are, or will soon become, viable in New York, mostly in high-value locations in New York City and Long Island. A companion analysis quantified over \$3 billion in gross ratepayer benefits from New York's deployment of 2,800 to 3,600 MW of energy storage by 2030.

**The key to harnessing energy storage** as a beneficial resource for our nation's electric grid is **twofold**. First, policies and rules must be established that **allow storage assets to provide multiple services** at the wholesale, distribution, and customer levels. Second, **storage assets must be fairly compensated**. Doing so will enable the optimal deployment of storage assets and create a stable environment for longer-term investment and financing. Energy storage is a complex set of technologies, and integrating them cost-effectively into the electric grid while maintaining safety, reliability, and affordability is no small task. I applaud the Subcommittee's leadership in addressing this challenge and look forward to providing my expertise in whatever ways might be helpful.

---

<sup>1</sup> <https://www.ethree.com/e3-helps-new-york-state-develop-energy-storage-roadmap/>

## Introduction

Thank you, Chairman Upton, Ranking Member Rush, and Members of the Subcommittee, for inviting me to testify on the topic of energy storage. My name is Kushal Patel and I am a Partner at Energy and Environmental Economics, Inc. (“E3”). E3 is an economic consulting firm based in San Francisco, California, that focuses exclusively on energy issues. We work across the U.S. on a diverse range of topics supporting numerous clients such as wholesale system operators, electric and natural gas utilities, public agencies, project developers, technology companies, and investors. E3 is able to serve such a broad client base because of our dedication to analytical rigor, our commitment to credibility and integrity, and our ability to think both creatively and realistically about today’s and tomorrow’s electric grid. This can be especially challenging given the sector’s complex and shifting dynamics, which include disparate state-level policy mandates; continuous technology innovation and cost declines; low natural gas prices; and consumers’ desire for more choice and control over their electricity supply.

E3 has analyzed today’s topic – the role of energy storage<sup>2</sup> in the nation’s electricity system – for over 20 years, starting with some of the earliest and most mature technologies like pumped storage-hydroelectric (pumped hydro), to current technologies like advanced lithium ion and flow batteries, to nascent technologies that may emerge over time. We have reviewed storage as both a stand-alone resource and one that is paired with generation (renewable or conventional). We have also looked at leveraging storage in multiple applications: participating directly in wholesale markets; as a “non-wires” solution that defers or avoids building transmission and/or distribution assets; and as a way for customers to reduce their electric bills.

I have almost 20 years of experience in the energy industry, primarily as a consultant. I lead E3’s Asset Valuation practice, which involves working closely with energy storage developers and investors

---

<sup>2</sup> The terms “energy storage” and “storage” are used interchangeably in this testimony.

throughout the U.S. I have provided developers and investors with various kinds of analytical and strategic support for over 2,000 MW of energy storage projects in the U.S. ranging from large (>500 MW) pumped hydro storage projects to small, customer-sited lithium-ion batteries. In 2016, I supported a major equity investor in its successful effort to execute the world's first-ever project financing of a large battery project, which is located in Southern California. My work also includes supporting a number of public agencies. Most recently, I worked with several New York state agencies to develop a comprehensive "roadmap"<sup>3</sup> for that state to reach a storage deployment target of 1,500 MW by 2025 and a larger, as-yet-unspecified target for 2030. It is expected that many of the recommendations presented in that roadmap will lead to a number of enforceable regulatory and programmatic actions by the state of New York beginning next year. It is also expected that New York's experience with deploying large amounts of energy storage over the next few years may inform similar efforts in other states.

The conclusion of my testimony, to which I will return, is as follows: **The key to harnessing energy storage** as a beneficial resource for our nation's electric grid is **twofold**. First, policies and rules must be established that **allow storage assets to provide multiple services** at the wholesale, distribution, and customer levels. Second, **storage assets must be fairly compensated**. Doing so will enable the optimal deployment of storage assets and create a stable environment for longer-term investment and financing.

## What Services Can Energy Storage Technologies Provide?

Energy has been called the "Swiss Army knife" of the electricity grid in recognition of the many services it can perform. Some services<sup>4</sup> are mutually exclusive and cannot be performed at the same time, while others can be "stacked" and performed at the same time and/or by the same resource. This flexibility is

---

3

<https://www.nyseda.ny.gov/All%20Programs/Programs/Energy%20Storage/Achieving%20NY%20Energy%20Goals/The%20New%20York%20State%20Energy%20Storage%20Roadmap>; <https://www.governor.ny.gov/news/governor-cuomo-announces-new-york-energy-storage-roadmap-achieve-nation-leading-target-1500>;

<sup>4</sup> Note, certain services can be performed singly or combined to construct energy storage "use cases" for examination/analysis.

especially important as our electric system evolves to become more decarbonized, decentralized, and complex.<sup>5</sup> Our current electric system was designed to operate with conventional assets, which are long-lived, relatively inflexible, “lumpy”, fixed-in-place, and single-use. By contrast, storage offers flexible, modular, mobile, and potentially multi-use assets that can provide a range of services to the wholesale market as well as the distribution system and individual customers. Ultimately, the type, number, and value of services that storage can provide are likely to change as the needs of the electric system change and storage technology advances. This means that certain services may be valuable in the near-term and for perhaps only short periods of time, while others may not be valuable until further in the future. Generally, storage technologies cannot perform all services of which they are capable simultaneously, which creates a need for clear market rules as well as performance, dispatch, and control requirements and signals in order to enable maximum and reliable value at minimum cost.

It is also important to remember that energy storage is much more than just large-scale lithium ion batteries. Rather, storage is a complex set of technologies<sup>6</sup>, including some that have supported the U.S. electric grid for decades (e.g., large pumped hydro); some more recent technologies like flywheels and thermal storage (e.g., ice, hot water, molten salt); and other technologies that are still in the research and development phase. These technologies differ in terms of their performance, scale, and other physical and economic characteristics (see Figure 1), and policy makers must keep these differences in mind as they seek to deploy energy storage solutions.

---

<sup>5</sup> This complexity will most likely take the form of a system with two-way power flow characterized by more renewable, intermittent energy; increasing diversity of end-uses and customer preferences; greater levels of data analytics and control technologies, the potential electrification of the heating and transportation sectors of the economy; and the need for increased system resiliency and lower costs to maintain a safe, affordable, and reliable electric system.

<sup>6</sup> Energy storage can be based on **chemical, electric, thermal, and mechanical** technologies. Chemical technologies include lithium-ion and flow batteries under various chemistries as well as fuel cells. Electrical technologies consist of superconductors or capacitors. Thermal technologies include molten salt, ice, and hot water storage. Mechanical technologies include pumped storage-hydroelectric, compressed air, and flywheel storage.

Figure 1: How to group energy storage technologies by the services they perform.

+ Can perform service    ± May perform service under certain circumstances    - Cannot perform service

Market	Service (Value/Benefit)	Timescale	Chemical	Electrical	Thermal	Mechanical
Wholesale	Frequency Regulation	Seconds, minutes	+	+	-	+
	Load Following/Ramping	Seconds, minutes, hours	+	+	-	+
	Renewable Integration	Seconds, minutes, hours, days, seasons	+	+	-	+
	Spinning Reserves	Minutes, hours	+	+	-	+
	Non-Spinning Reserves	Minutes, hours	+	+	-	+
	Voltage Support	Minutes, hours	+	+	-	+
	Black Start	Minutes, hours	+	+	-	+
	Energy (arbitrage, peak shaving, shifting)	Minutes, hours, days	+	+	-	+
	Emission Reductions	Minutes, hours, days, months, seasons, years	±	±	±	±
	System Capacity or Resource Adequacy	Months, years	+	-	-	+
	Transmission Deferral/Avoidance	Months, years	+	-	-	+
Distribution	Volt/VaR Control	Seconds, minutes	+	-	-	-
	Outage Mitigation	Minutes, hours, days	+	-	-	-
	DG integration	Minutes, hours, days	+	-	-	-
	Distribution Deferral/Avoidance	Months, years	+	-	-	-
	Distribution Congestion Relief	Months, years	+	-	-	-
Retail (Customer or Ratepayer)	Power Reliability	Seconds, minutes, hours	+	-	-	-
	Backup Power	Minutes, hours	+	-	-	-
	Utility Delivery Charge Savings	Minutes, days, months	+	-	±	-
	Retail Commodity Charge Savings	Hours, days, months	+	-	±	-

Energy storage is expected to play an ever larger role in the electric grid because of the variety of benefits it can provide to customers, utilities, and the wholesale markets. These include helping to manage individual customers' electric bills; helping to lower utilities' infrastructure costs (which benefits utility ratepayers); and helping to lower wholesale system operating costs (which benefits consumers), particularly as larger amounts of renewable and less-emitting energy sources come online in the future.

Figure 2 below summarizes E3's market outlook for energy storage in the U.S. Current barriers limiting cost-effective storage deployment include the high (but declining) cost of storage and, more importantly, its limited ability to earn revenues for the numerous services it can perform. Costs of energy storage are expected to continue declining rapidly over the next few years in parallel with technology innovation and market evolution; this will allow for more cost-effective deployment, especially if more supportive policies and regulatory actions are introduced.

Figure 2: How will the U.S. market for energy storage evolve?

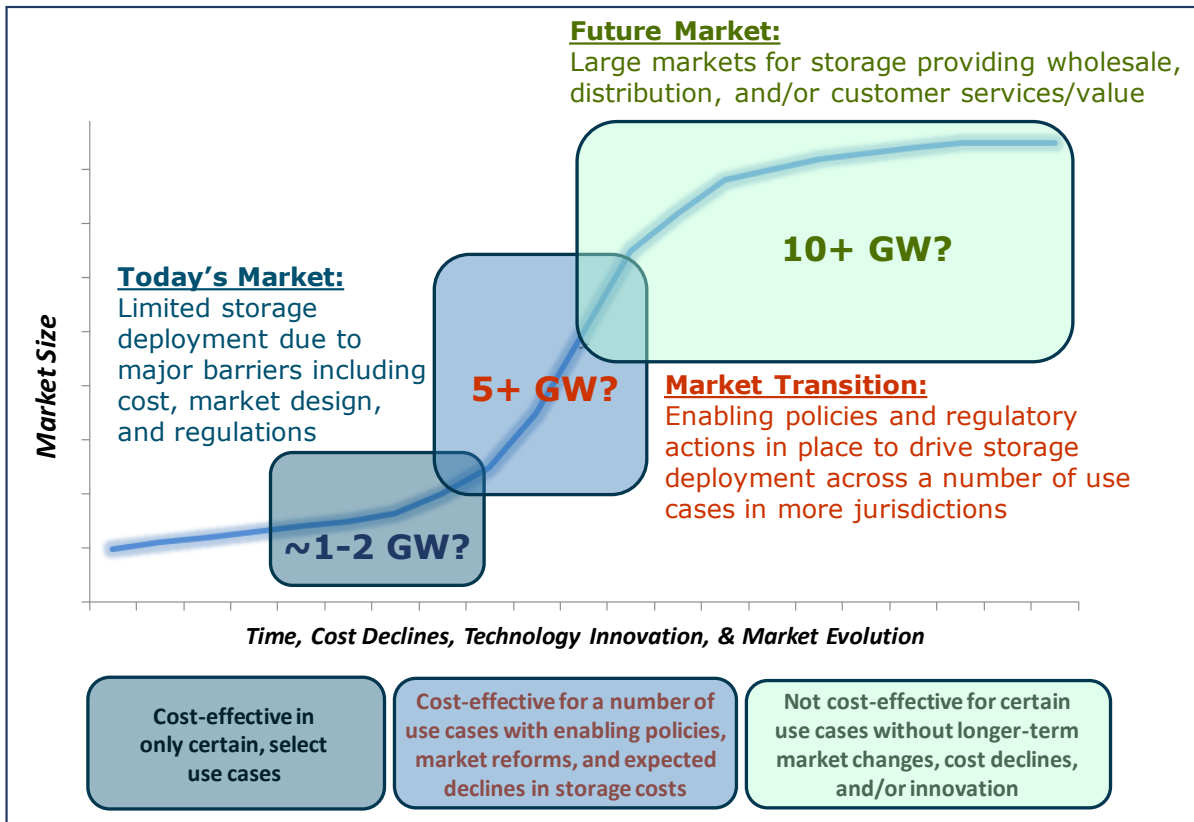

Nevertheless, the current barriers to storage are substantial. Clear routes to market exist for only a limited number of storage services; others cannot currently be monetized, while still others, such as those related to integrating larger amounts of renewable energy, may not become valuable until the future. Consequently, some storage benefits remain unrealized; this is especially true of services that can be stacked, either at the same time or with the same resource over time. The primary challenges facing storage, especially advanced energy storage include:

- **The inability to monetize the full value of storage.** Current operating restrictions and/or high costs from aggregation or telemetry that would enable monetizing multiple stacked services are one of the largest barriers to storage. The inability to fully monetize storage limits its value, and therefore its economics, in today's electricity markets.
- **Limited routes to existing markets.** Regulatory and market rules, which were put in place largely before resources like advanced energy storage were available, often limit the ability of storage to receive appropriate compensation. In some cases, these rules do not fully recognize the value of storage's near-instantaneous response as compared to alternatives in today's markets.
- **Confidence in performance and lifetime.** The diversity and relative "newness" of different types of energy storage technologies, products, applications, and use cases complicate understanding and confidence among potential customers, system operators, and investors.
- **Lack of common financing vehicles.** The relatively low volume of existing advanced energy storage projects contributes to a lack of standardized and transparent processes, procedures, and documentation, which in turn impedes investor confidence and traditional financing and increases transaction costs.
- **High costs** of hardware and "soft costs" related to permitting, siting, interconnection, customer acquisition, and financing.
- **Insufficient data and lack of situational awareness of the electric system,** which impedes efforts to site energy storage for maximum system benefit and identify potential customers.

Some of the key factors driving energy storage adoption include:

- **Declining costs** averaging 10-15 percent per year, which are forecasted to continue through at least the early 2020s.
- **Better performance and longevity** of different energy storage technologies.
- **Increasing investment appetite** among developers and financiers.
- **Improved understanding** of the value provided by energy storage.
- **Policy and regulatory commitments** such as targeted energy storage incentives, utility procurement targets for energy storage and renewables, and wholesale/distribution market participation models for energy storage.



## What is the Status of Energy Storage in the U.S.?

Currently the largest U.S. energy storage markets – California and Hawai'i – are driven by utility procurement mandates, state incentives, and high renewable penetration. New York<sup>7</sup>, Massachusetts, and New Jersey are poised to become large energy storage markets, while markets such as Arizona, Nevada, Illinois, and Texas are not far behind. A number of diverse storage applications are being piloted and deployed at scale to provide resource adequacy and local distribution value (in California) and to help integrate rooftop solar and large-scale renewables (in Hawai'i). There is a pipeline of projects in the development stage as well as a large number of projects in the planning stage, including potential hybridization<sup>8</sup> of existing conventional power plants.

Figure 3 gives an overview of the U.S. energy storage market, showing approximately 25 GW of existing energy storage with an additional 7.8 GW announced, planned, and/or under construction.<sup>9</sup> The majority of existing energy storage is in the form of large pumped hydro while projects that have been announced, planned, and/or under construction represent a mix of technologies including large lithium ion batteries.

---

<sup>7</sup> New York State has currently deployed approximately 60 megawatts (MW) of advanced energy storage capacity, with another 500 MW in the pipeline. (This is in addition to its 1,400 MW of traditional pumped hydro.) Under the State's energy storage target, its advanced (non-hydro) storage will grow to 1,500 MW by 2025. Studies performed by Acelerex quantified over \$3 billion in gross ratepayer benefits from New York's deployment of 2,800-3,600 MW of energy storage by 2030.

<sup>8</sup> This is where energy storage is added to an existing conventional resource to enhance operations, increase revenues, etc.

<sup>9</sup> S&P Global Market Intelligence data from March 2018.

Figure 3: U.S. energy storage market (with and without large pumped hydro).

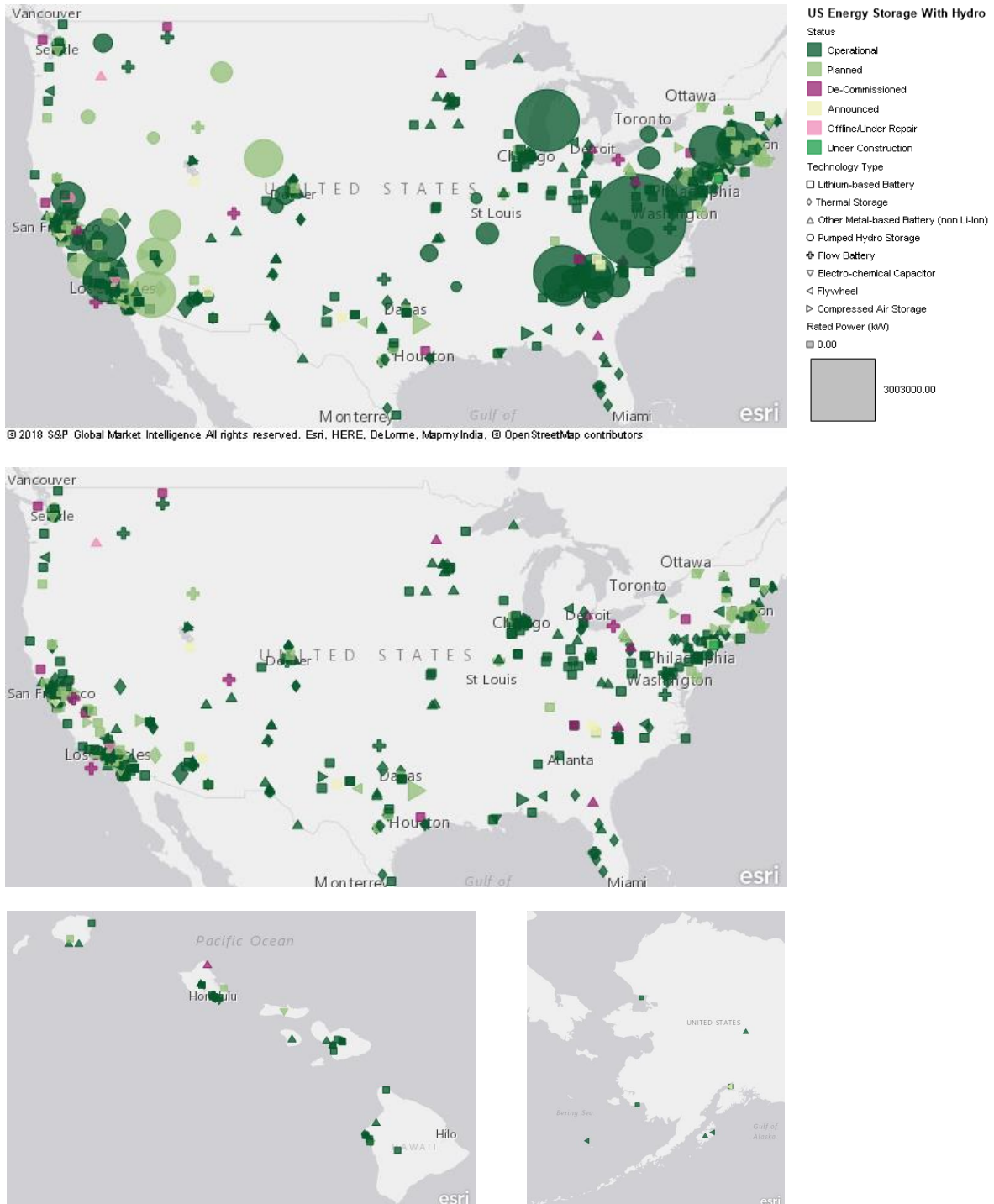

## How is New York Accelerating Energy Storage Deployment?

New York is poised to join California and Hawai'i as one of the leading markets for advanced energy storage in the U.S. Earlier this year, Governor Andrew M. Cuomo announced a statewide target to install 1,500 megawatts of energy storage by 2025. In response, state agencies developed the New York Energy Storage Roadmap, an analytically driven set of recommended policy, regulatory, and programmatic actions that represent the best near-term opportunities to support energy storage deployment. These recommendations address barriers that can realistically be remedied on the path to reaching New York's 2025 storage target as it explores an even more ambitious target for 2030.

The roadmap focuses on near-term actions to allow New York to deploy storage in ways that are viable, replicable, and scalable for storage projects that are customer sited as well as sited in the distribution and bulk system (i.e. the wholesale market). It does this by focusing on the storage applications that provide the most value to the system while minimizing overall costs to customers. Accelerating storage deployment in the near term was important to New York for several reasons, including reducing “soft costs” (i.e., non-hardware costs) such as permitting and customer acquisition; increasing awareness and confidence in the ability of energy storage to meet electric system needs; and expanding customer choice by increasing the number of developers selling storage solutions in New York.

The roadmap examined a large and diverse number of energy storage use cases that informed the recommended actions, which can be seen in Figure 4 below.

Figure 4: Categories of use cases analyzed in the New York State Energy Roadmap.

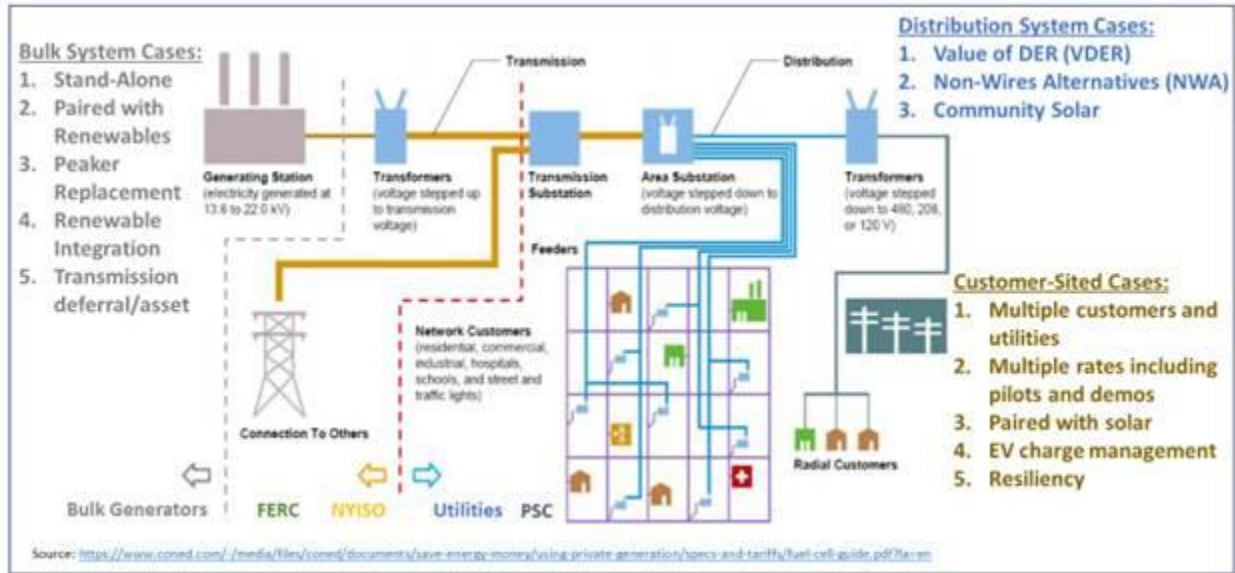

The roadmap found that **many customer-sited and distribution system use cases and paired solar + storage projects are, or will soon become, viable in downstate New York between now and 2025.** This is due to better storage project economics, where higher value streams offset higher costs. Economically attractive opportunities to pair storage with renewables and potentially to hybridize and/or replace fossil peaking units will also begin to arise, as will high-value distribution system use cases in upstate New York. In the longer term, numerous diverse use cases will become economic across New York, especially as the system adds more renewables and the cost of storage solutions continues to decline. Importantly, there will also be cases in which project economics far surpass the illustrative economics shown in the roadmap due to different load shapes and local electric system needs.

The roadmap’s key takeaways are as follows:

- **Value stacking** – allowing storage to perform and be compensated for multiple services, especially at the wholesale market level – **is essential to maximizing its value.** A Swiss Army knife is just a regular knife if you only use the blade and not its other tools.
- Creating rules and structures to allow for **“dual market” participation** is a key priority so that individual energy storage assets can participate, provide value, and be compensated for both services at the retail/distribution level as well as the wholesale market level.

- There will be an evolution of the market for energy storage as barriers are removed and markets evolve. In the near term, only **certain high-value energy storage use cases or applications will be cost-effective** absent incentives or radical market changes; over time, more and more use cases will become economic, replicable, and scalable.
- **Revenue certainty** is needed to enable investment and financing of energy storage given its 10-20 year asset life and high upfront costs.
- A **market acceleration “bridge” incentive** may be justified to accelerate energy storage deployment. Such an incentive would “buy” 1-2 years’ worth of expected storage cost declines in order to bend the overall cost curve downward, producing net savings to customers and reducing future storage costs to meet public policy goals.

The roadmap was developed to drive storage deployment (as per Figure 5 below) by:

1. **Engaging stakeholders** across customers, utilities, the system operator (NYISO), and various other market participants through working groups, conferences, and individual meetings, and leveraging their input.
2. **Identifying and modeling storage deployment use cases** to reflect an extensive but not exhaustive range of potential installations and customer types.
3. **Recognizing key challenges and barriers**, and formulating actions to address them.
4. **Conducting an in-depth analysis** of each use case to evaluate and analyze storage value; develop, inform, and test potential recommended actions; estimate potential market uptake; and develop implementation pathways.
5. **Developing a set of recommended actions** that immediately begin transitioning New York’s storage market to the desired end state: a self-sustaining market that responds to system needs and price signals and yields maximum benefit for customers. Importantly, the roadmap is technology-agnostic and recognizes that a range of storage solutions will be deployed to best meet customer and system needs.

Figure 5: The many aspects of unlocking storage value and deployment.

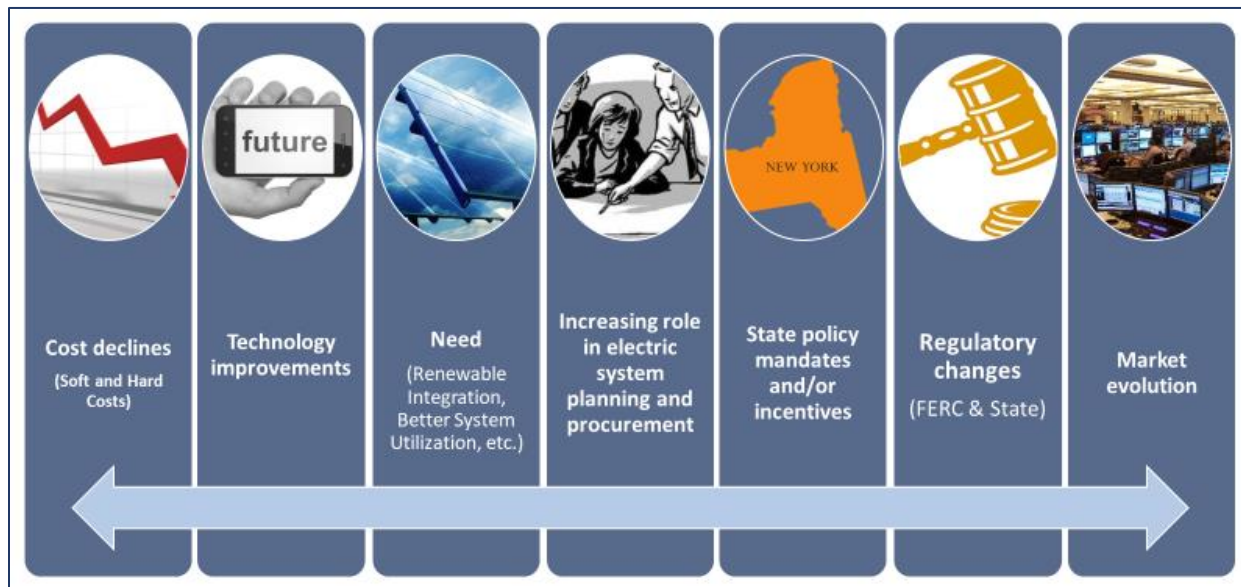

## Conclusion: The Future of Energy Storage

Energy storage is poised to assume the primary role in providing many grid services, especially at the wholesale market level as its costs decline. Energy storage can and will perform an increasing number of services as technology evolves and costs continue to decline, but **key enabling policies and regulations are needed.**

For years, E3 has been analyzing energy storage and how the electric grid and its various markets across the U.S. might evolve. We feel there is significant value in energy storage, especially when wholesale market services can be stacked on top of retail and distribution services. Specific approaches to value stacking will almost certainly change over time; because the electric grid is evolving at all levels (i.e., retail, distribution, and wholesale), the potential benefits of storage, and the mechanisms for utilizing and compensating those benefits, will evolve as well.

In conclusion, **the key to harnessing energy storage** as a beneficial resource for our nation's electric grid **is twofold.** First, policies and rules must be established that **allow storage assets to provide multiple services** at the wholesale, distribution, and customer levels. Second, **storage assets must be fairly compensated.** Doing so will enable the optimal deployment of storage assets and create a stable environment for longer-term investment and financing.

Energy storage, which most people think of simply as large-scale batteries, is actually a complex set of technologies, and integrating them cost-effectively into the electric grid – while maintaining safety, reliability, and affordability – is no small task. I applaud the Subcommittee's leadership in addressing this challenge, and look forward to providing my expertise and perspective in whatever ways might be helpful.

Thank you.